

MIC-3753

72-ch Digital I/O Card

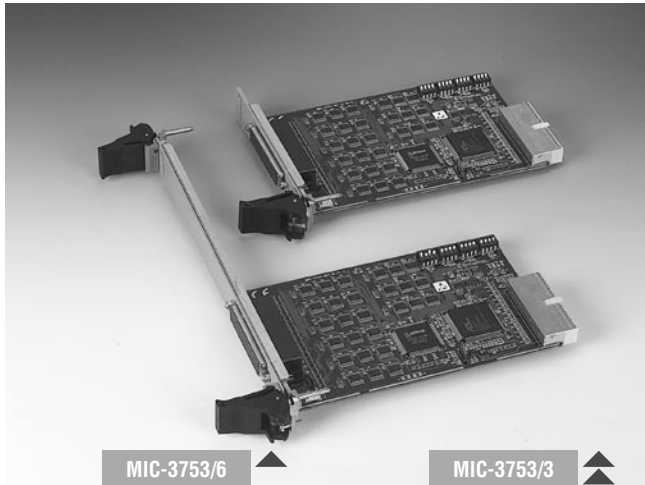

CE FCC

Features

- 72 TTL digital I/O lines
- Emulates mode 0 of 8255 PPI
- Buffered circuits for higher driving capacity than 8255
- Multiple-source interrupt handling
- Interrupt output pin for simultaneously triggering external devices with the interrupt
- Output status read-back
- "Pattern match" and "Change of state" interrupt functions for critical I/O monitoring
- Keeps I/O setting and digital output values when hot system reset
- Supports dry contact and wet contact

Introduction

The MIC-3753 is a 72-channel digital I/O card for the PCI bus. The card emulates mode 0 of the 8255 PPI chip, but the buffered circuits offer a higher driving capability than the 8255. The 72 I/O lines are divided into nine 8-bit I/O ports: A0, B0, C0, A1, B1, C1, A2, B2, C2. Users can configure each port as input or output via software.

Easy to Install: Plug & Play

The MIC-3753 uses a PCI controller to interface the card to the PCI bus. The controller fully implements the PCI bus specification Rev 2.1. All bus relative configurations, such as the base address and interrupt assignments, are automatically controlled by software.

Dry Contact Support for Digital Input

Each digital input channel of the MIC-3753 accepts either 0 ~ 5 V_{DC} wet contact or dry contact inputs. This dry contact capability allows the channels to respond to changes in external circuitry (e.g., the closing of a switch in the external circuitry) when no voltage is present in the external circuit.

Reset Protection Fulfills the True Requirement of Industrial Applications

When the system is hot reset (the power is not turned off), the MIC-3753 can either retain the value of the last I/O port settings and outputs, or return to its default configuration, depending on the jumper setting. This function protects the system from wrong operations during unexpected system resets.

Interrupt Functions Ensure Faster System Response

Two lines of each port C (i.e., ports C0, C1 and C2) are connected to an interrupt circuit. The "Interrupt Control Register" of the MIC-3753 controls how these signals generate an interrupt. Two interrupt request signals can be generated at the same time, and the software can process these two request signals by ISR. The dual interrupt sources provide the card with more capability and flexibility.

The MIC-3753 also provides a "Pattern Match" interrupt function for port A0. The card monitors the states of port A0 and compares them with a pre-set pattern. When the received state matches the pre-set pattern, the MIC-3753 generates an interrupt signal to the system.

A "Change of State" interrupt function is provided at port B0. When any signal line of port B0 changes its state, the card generates an interrupt to the system to handle this event.

These interrupt functions release the CPU from the burden of pulling all I/O points, enabling a PC to handle more I/O points with higher performance.

Specifications

- **I/O Channels** 72 digital I/O lines
- **Programming Mode** 8255 PPI mode 0
- **Input Signal** Logic level 0: 0.8 V max.
Logic level 1: 2.0 V min.
- **Output Signal** Logic level 0: 0.44 V max. @ 24 mA (sink)
Logic level 1: 3.76 V min. @ 24 mA (source)
- **Transfer Rate** 1.6 MB/s (tested under DOS, K6 300 MHz CPU)
- **Power Consumption** +5 V @ 400 mA (typical), +5 V @ 0.7 A (max.)
- **Operating Temperature** 0 ~ 60° C (32 ~ 140° F) (refer to IEC 68-2-1, 2)
- **Storage Temperature** -20 ~ 70° C (-4 ~ 158° F) (refer to IEC 68-2-3)
- **Operating Humidity** 5 ~ 95% RH non-condensing
- **Connector** One 78-pin D-type female connector
- **Dimensions (LxH)** 160 x 100 mm (6.3" x 3.9"), 3U/6U Bracket

Ordering Information

- **MIC-3753/3** 3U 72-channel Digital I/O Card, user's manual and driver CD-ROM. (cable not included)
- **MIC-3753/6** 6U 72-channel Digital I/O Card, user's manual and driver CD-ROM. (cable not included)
- **PCL-10178-1** DB-78 cable assembly, 1 m
- **ADAM-3978** DB-78 wiring terminal for DIN-rail mounting

Applications

- Industrial AC/DC I/O devices for monitoring and controlling
- Relay and switch monitoring and controlling
- Parallel data transfer
- TTL, DTL and CMOS logic signal sensing
- Indicator LED driving

Block Diagram

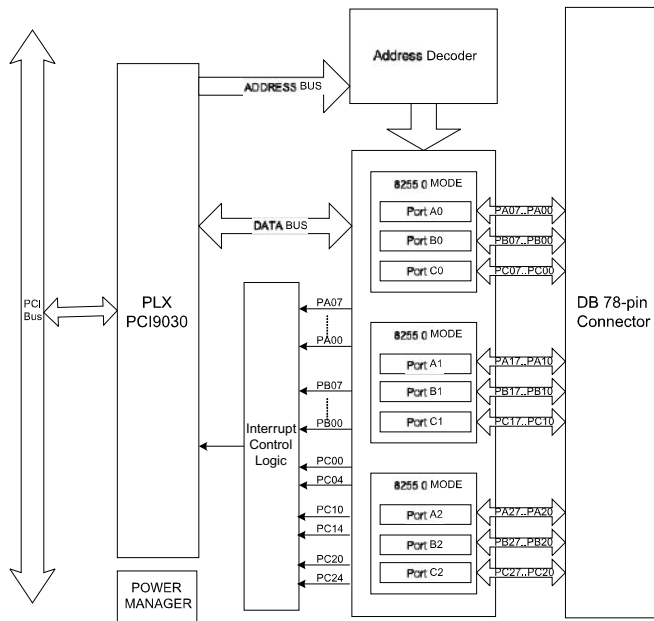

MIC-3753 Block Diagram

Pin Assignments

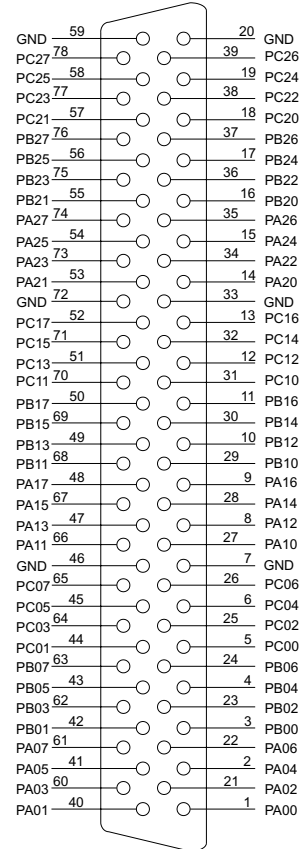

- | | |
|--------------|---------------------|
| PA00 ~ PA07 | I/O pins of Port A0 |
| PA10 ~ PA17 | I/O pins of Port A1 |
| PA20 ~ PA27 | I/O pins of Port A2 |
| PB00 ~ PB07 | I/O pins of Port B0 |
| PB10 ~ PB17 | I/O pins of Port B1 |
| PB20 ~ PB27 | I/O pins of Port B2 |
| PC00 ~ PC07 | I/O pins of Port C0 |
| PC10 ~ PC17 | I/O pins of Port C1 |
| PC20 ~ PC27 | I/O pins of Port C2 |
| GND : Ground | |